

CHICAGO POWER ELECTRIC® SYSTEMS

CHARGER / ENGINE STARTER, 6/12V

Model 46944

ASSEMBLY and OPERATING INSTRUCTIONS



Diagrams within this manual may not be drawn proportionally.
Due to continuing improvements, actual product may differ slightly from the product described herein.

Distributed exclusively by Harbor Freight Tools®.

3491 Mission Oaks Blvd., Camarillo, CA 93011

Visit our website at: <http://www.harborfreight.com>



**Read this material before using this product.
Failure to do so can result in serious injury.
SAVE THIS MANUAL.**

Copyright© 2002 by Harbor Freight Tools®. All rights reserved. No portion of this manual or any artwork contained herein may be reproduced in any shape or form without the express written consent of Harbor Freight Tools.

For technical questions or replacement parts, please call 1-800-444-3353.

Specifications

Amperage Output (6 and 12 Volt)	40 amps at 6 Volts 100 amps at 6 Volts intermittent 2/10/40 amps at 12 Volts 200 amps at 12 Volts intermittent
Timer	3 Hour
Dimensions	16" W x 11-3/4" D x 31-3/4" H
Cable Clamps	3/4" W x 6-1/2" L (Copper), 3-3/4" L, Color Coded Vinyl Grip Sleeves, Red (Positive), Black (Negative)
Cable Length	79"

Save This Manual

You will need the manual for the safety warnings and precautions, assembly instructions, operating and maintenance procedures, parts list and diagram. Keep your invoice with this manual. Write the invoice number on the inside of the front cover. Keep the manual and invoice in a safe and dry place for future reference.

Safety Warnings and Precautions

WARNING: When using tool, basic safety precautions should always be followed to reduce the risk of personal injury and damage to equipment.

Read all instructions before using this tool!

1. **Keep work area clean.** Cluttered areas invite injuries.
2. **Observe work area conditions.** Do not use machines or power tools in damp or wet locations. Don't expose to rain. Keep work area well lighted. Do not use electrically powered tools in the presence of flammable gases or liquids.
3. **Keep children away.** Children must never be allowed in the work area. Do not let them handle machines, tools, or extension cords.
4. **Store idle equipment.** When not in use, tools must be stored in a dry location to inhibit rust. Always lock up tools and keep out of reach of children.
5. **Do not force tool.** It will do the job better and more safely at the rate for which it was intended. Do not use inappropriate attachments in an attempt to exceed the tool capacity.
6. **Use the right tool for the job.** Do not attempt to force a small tool or attachment to do the work of a larger industrial tool. There are certain applications for which this tool was designed. Do not modify this tool and do not use this tool for a purpose for which it was not intended.
7. **Dress properly.** Do not wear loose clothing or jewelry as they can be caught in moving parts. Protective, electrically nonconductive clothes and nonskid footwear are recommended when working. Wear restrictive hair covering to contain long hair.
8. **Use eye protection.** Always wear ANSI approved impact safety goggles.

9. **Do not overreach.** Keep proper footing and balance at all times. Do not reach over or across running machines.
10. **Maintain tools with care.** Keep tools clean for better and safer performance. Inspect tool cords periodically, and if damaged, have them repaired by an authorized technician. The handles must be kept clean, dry, and free from oil and grease at all times.
11. **Disconnect power.** Unplug Charger Engine Starter when not in use.
12. **Avoid unintentional starting.** Be sure the switch is in the Off position when not in use and before plugging in.
13. **Stay alert.** Watch what you are doing, use common sense. Do not operate any tool when you are tired.
14. **Check for damaged parts.** Before using any tool, any part that appears damaged should be carefully checked to determine that it will operate properly and perform its intended function. Check for alignment and binding of moving parts; any broken parts or mounting fixtures; and any other condition that may affect proper operation. Any part that is damaged should be properly repaired or replaced by a qualified technician. Do not use the tool if any switch does not turn On and Off properly.
15. **Guard against electric shock.** Prevent body contact with grounded surfaces such as pipes, radiators, ranges, and refrigerator enclosures.
16. **Replacement parts and accessories.** No replacement parts available.
17. **Do not operate tool if under the influence of alcohol or drugs.** Read warning labels on prescriptions to determine if your judgment or reflexes are impaired while taking drugs. If there is any doubt, do not operate the tool.
18. **Use proper size and type extension cord.** If an extension cord is required, it must be of the proper size and type to supply the correct current to the tool without heating up. Otherwise, the extension cord could melt and catch fire, or cause electrical damage to the tool. This tool requires use of an extension cord of **0 to 15 amps** capability (up to 25 feet), with wire size rated at **16 AWG**. Longer extension cords require larger size wire. If you are using the tool outdoors, use an extension cord rated for outdoor use (signified by "WA" on the jacket).
19. **Maintenance.** For your safety, maintenance should be performed regularly by a qualified technician.

Note: Performance of this tool (if powered by line voltage) may vary depending on variations in local line voltage. Extension cord usage may also affect tool performance.

Warning: The warnings, cautions, and instructions discussed in this instruction manual cannot cover all possible conditions and situations that may occur. It must be understood by the operator that common sense and caution are factors which cannot be built into this product, but must be supplied by the operator.

Additional Battery Charger Safety Warnings:

1. Only use this Charger Engine Starter with lead acid, rechargeable type batteries. Remove battery caps to check liquid level inside battery. If liquid is not present or if liquid appears to be frozen, do not attempt to charge battery.
2. Do not use this Charger Engine Starter as a low voltage system power supply except in automotive applications.
3. Do not try to start the automobile engine when the battery is still charging. It may damage the unit.
4. Do not use this Charger Engine Starter to charge household dry cell batteries. Dry cell batteries may explode causing personal injury and property damage.
5. Always charge lead acid batteries in well ventilated areas as explosive gases may be produced during charging.
6. Place the Charger Engine Starter as far away as possible from the battery you are charging.
7. Never attempt to charge a battery with frozen fluid.
8. Be careful not to drip any fluids in or around the Charger Engine Starter. Damage to the Charger Engine Starter can occur.
9. Never touch the Charger Engine Starter cable clamps together when the charger is plugged in; touching the cables together will cause sparking and possible personal injury and/or property damage.
10. Do not touch your eyes after working with a lead acid battery. Wash your hands thoroughly with soap and water.
11. If battery fluids contact your skin, face, or eyes, immediately flush with plenty of fresh water, and then contact a doctor.
12. Never smoke around a charging battery.
13. Make all cable clamp connections before plugging in the Charger Engine Starter.
14. Remove all metal objects (including tools, personal objects such as a watch or jewelry) from around the battery being charged.
15. Don't use the Charger Engine Starter in damp or wet locations.

How Batteries Charge.

A charger doesn't force current into a battery, but makes a limited amount available, and the battery draws what it needs, up to or slightly greater than the output amp rating of the charger.

The closer the battery is to zero charge, the more current is drawn. Beginning with a dead battery, the charger's ammeter registers toward the high amp end, and falls toward zero as charging progresses. Remember, the ammeter registers the amount of current being drawn from the battery, not the delivery capability of the charger.

After the charger reaches 100% charge, it continues to draw on low level, converting it into heat inside the battery. If left connected, after a full charge, the battery acid will eventually boil, overcharging and damaging the battery.

Warning!! This Charger Engine Starter doesn't have an automatic cut off. It is equipped with a 2-1/2 hour timer. Always check the battery and the time manually. Don't depend solely on the timer. Leaving the Charger Engine Starter unattended can result in property damage and/

Unpacking

When unpacking, check to make sure the parts listed on page 8 are included. If any parts are missing or broken, please call Harbor Freight Tools at the number on the cover of this manual as soon as possible.

Assembly

Refer to FIGURE 1 and FIGURE 2 below.

1. Place the Charger Engine Starter on its side.
2. Mount the Mounting Foot on the bottom using three screws.

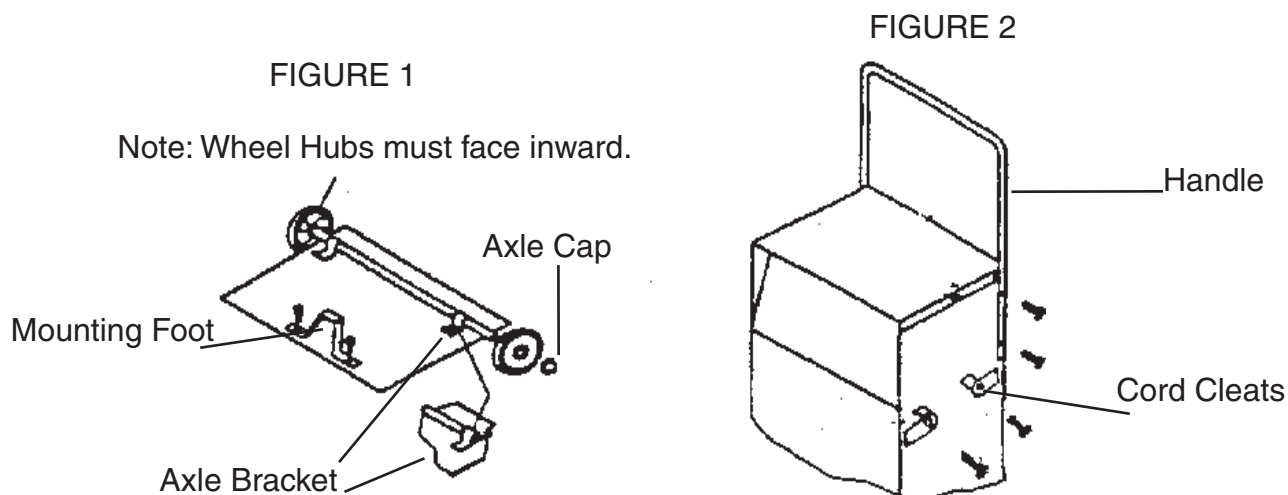

3. Next, slide the Wheels on the Axle and put an Axle Cap on each wheel. Pound on the Axle Caps with a rubber mallet. Make sure the Hubs are facing in on each wheel.
 4. Line up the Axle Brackets with the holes on the bottom of the Charger and screw the Axle Bracket to the bottom of the Charger Engine Starter.
 5. Stand up the unit.
 6. Remove the two top screws on each side of the Charger Engine Starter. Place the Handle so it lines up with the screw holes, and replace the screws, securing the Handle.
 7. Mount the six Cord Cleats using the remaining six screws.
- Assembly complete.

Operation

1. Place the Charger Engine Starter at least five feet from the battery to be charged.
2. If the battery is to be charged in a vehicle, make sure the ignition is off and the key is removed. Then, connect the positive (red with + sign) cable clamp to the positive (P or +) terminal of the battery.
3. Connect the negative (Black with the - sign) to an unpainted solid metal portion of the vehicle.
4. Set the Charger Engine Starter Switch to the proper setting for the type of battery being charged. Refer to Table 1 on Page 6.
5. With the battery clamps in place, and the Rotary Switch correctly set, plug the 3-prong line cord into a grounded electrical outlet or extension cord.
6. The Charger Engine Starter is now supplying charging current to the battery. View the Ammeter to see the amount of charging current. (The Ammeter displays the amount of the "current draw" of the battery. As it charges, it draws less current. The Ammeter moves toward zero as the battery charges.)

Operation (continued)

7. After fully charging the battery, when the ammeter needle reads zero nearly, unplug the Charger Engine Starter line cord from the outlet or extension cord.
8. Remove the negative (black) cable clamp from the battery.
9. Remove the positive (red) cable clamp from the battery.

Table 1

Battery Size / Rating			Charge Rate* / Charging Time Hours**		
			12V 2 Amp	12V 10 Amp	12/6V 40 Amp
Small Batteries	Motorcycle	6 - 12 AH	3 - 6	NR	NR
	Garden Tractor etc.	12 - 32 AH	3 - 18		
Cars / Trucks	200 - 315 CCA	40 - 60 RC	13 - 20	2-1/2 - 4	1/2 - 3/4
	315 - 550 CCA	60 - 85 RC	20 - 35	4 - 7	3/4 - 2
	550 - 875	85 - 125 RC	35 - 55	7 - 11	2 - 3

Notes: * Charge Rates for this model are listed on the front panel.

** Based on battery at 50% charge.

AH = Ampere Hours

NR = Not Recommended

CCA = Cold Cranking Amps

RC = Reserve Capacity

Warning!! This Charger Engine Starter is not automatic and can overcharge and dry up a battery if permitted to operate for extended periods of time. Monitor the charging often.

Output Selector Controls

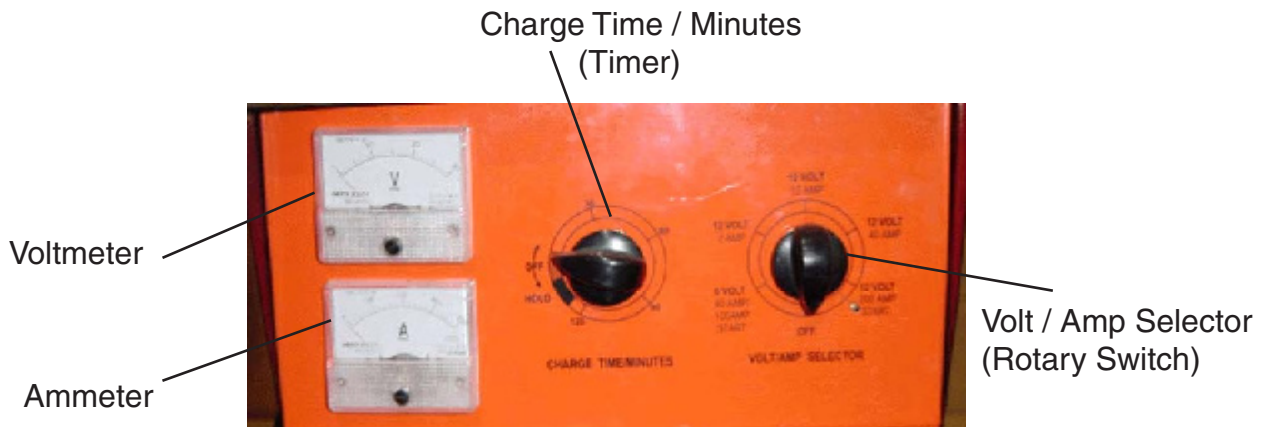

Timer: The main function of the timer is to prevent over charging while allowing a battery time to obtain a satisfactory charge. To properly set the timer, you must know the size of the battery in ampere hours or reserve capacity in minutes, and the state of charge. Often the state of charge is not known, which is one reason why the timer is limited to 3 hours. With the aid of a battery load tester (not included) the state of the charge can be obtained in a few seconds. For example, the average size automotive battery at a 50% state of charge will

Operation (continued)

require 1 to 1-1/2 hours of charging at the 40 amp rate to reach the full charge state. For the same battery with its timer set to maximum, 3 hours overcharging will occur. Slight overcharging will not likely harm a battery that was otherwise in good condition. When the state of charge is unknown, start out with a timer setting of one hour or less.

Hold: This position defeats the timer function, allowing for continuous operation. Use it when you want to charge more than 3 hours. This is normally used when the 2 amp charge rate is selected. Be sure to monitor the charging and stop the charge when the battery is fully charged.

Rotary Switch: Use the rotary switch to select the charge rate or engine start setting you require. Read the switch dial for the appropriate setting.

Ammeter: The ammeter indicates the amount of current measured in amperes that's drawn from the battery. For example, in the 40 amp charge rate a typical discharged battery will initially draw approximately 40 amps. As the battery continues to charge, current will taper to 15 to 20 amps at full charge. When cranking an engine, the starter motor draws upward to 200 amps. The meter needle will be at the extreme right side. The 2 amp charge rate may indicate some activity on the meter. The meter doesn't have the resolution to display this low rate.

Engine Start

1. Set the charge rate and timer to the off positions.
2. With the Charger unplugged from the AC outlet, connect the Charger to the battery.
3. Plug the Charger AC power cord into the AC outlet, then move OFF to HOLD position.
4. Set the charge rate to the engine start position that matches the vehicle battery, and then crank the engine. Follow the duty cycle printed on the front panel of your charger for proper ON/OFF times. During extremely cold weather, or when the battery is severely exhausted, charge the battery for about five minutes before attempting to crank the engine.
5. If the engine fails to start, charge the battery for five more minutes before cranking the engine.
6. After the engine starts, move the charge rate switch to OFF and unplug the AC power cord from the outlet before disconnecting the DC cable clamps.

Troubleshooting

Symptom: Ammeter display reads maximum.

Probable Cause: Defective battery.

Remedy: Check or replace battery.

Symptom: No ammeter reading.

Probable Cause: 1. No power to charge. 2. Battery cables not making connection.

3. Two amp charge rate being used.

Remedy: 1. Check power and cable outlet connections. 2. Clean battery cables and reset cable clamps. 3. None, meter will not indicate here.

Symptom: Charging current not to full output.

Probable Cause: 1. Battery is partially charged. 2. Defective battery, will not hold full charge.

Remedy: 1. Continue charging. 2. Check and/or replace battery.

Troubleshooting (continued)

Symptom: Ammeter needle moves up to full charge, then drops to zero. Makes clicking noise.

Probable Cause: 1. Battery is completely dead. 2. Defective battery. 3. Charger Engine Starter is resetting itself after circuit overload. 4. Circuit breaker is cycling. 5. Reverse connections at battery.

Remedy: 1. Continue charging battery. Charger Engine Starter will continue to reset itself until the battery charge reaches a chargeable level. 2. Check and/or replace battery. 3. Wait until Charger automatically resets itself. 4. May be the wrong switch position. 5. Shut off Charger and correct cable lead connections.

Note: There are no replacement parts available with this Charger.

ACCESSORIES

1. Handle.....	1
2. Wheels	2
3. Axle	1
4. Mounting Foot	1
5. Axle Brackets	2
6. Cord Cleats	6
7. Bag of Hardware	1
8. Manual	1

NOTE: Some parts are listed and shown for illustration purposes only and are not available individually as replacement parts.

PLEASE READ THE FOLLOWING CAREFULLY

THE MANUFACTURER AND/OR DISTRIBUTOR HAS PROVIDED THE PARTS DIAGRAM IN THIS MANUAL AS A REFERENCE TOOL ONLY. NEITHER THE MANUFACTURER NOR DISTRIBUTOR MAKES ANY REPRESENTATION OR WARRANTY OF ANY KIND TO THE BUYER THAT HE OR SHE IS QUALIFIED TO MAKE ANY REPAIRS TO THE PRODUCT OR THAT HE OR SHE IS QUALIFIED TO REPLACE ANY PARTS OF THE PRODUCT. IN FACT, THE MANUFACTURER AND/OR DISTRIBUTOR EXPRESSLY STATES THAT ALL REPAIRS AND PARTS REPLACEMENTS SHOULD BE UNDERTAKEN BY CERTIFIED AND LICENSED TECHNICIANS AND NOT BY THE BUYER. THE BUYER ASSUMES ALL RISK AND LIABILITY ARISING OUT OF HIS OR HER REPAIRS TO THE ORIGINAL PRODUCT OR REPLACEMENT PARTS THERETO, OR ARISING OUT OF HIS OR HER INSTALLATION OF REPLACEMENT PARTS THERETO.

LIMITED 90 DAY WARRANTY

Harbor Freight Tools Co. makes every effort to assure that its products meet high quality and durability standards, and warrants to the original purchaser that this product is free from defects in materials and workmanship for the period of 90 days from the date of purchase. This warranty does not apply to damage due directly or indirectly, to misuse, abuse, negligence or accidents, repairs or alterations outside our facilities, criminal activity, improper installation, normal wear and tear, or to lack of maintenance. We shall in no event be liable for death, injuries to persons or property, or for incidental, contingent, special or consequential damages arising from the use of our product. Some states do not allow the exclusion or limitation of incidental or consequential damages, so the above limitation of exclusion may not apply to you. THIS WARRANTY IS EXPRESSLY IN LIEU OF ALL OTHER WARRANTIES, EXPRESS OR IMPLIED, INCLUDING THE WARRANTIES OF MERCHANTABILITY AND FITNESS.

To take advantage of this warranty, the product or part must be returned to us with transportation charges prepaid. Proof of purchase date and an explanation of the complaint must accompany the merchandise. If our inspection verifies the defect, we will either repair or replace the product at our election or we may elect to refund the purchase price if we cannot readily and quickly provide you with a replacement. We will return repaired products at our expense, but if we determine there is no defect, or that the defect resulted from causes not within the scope of our warranty, then you must bear the cost of returning the product.

This warranty gives you specific legal rights and you may also have other rights which vary from state to state.

3491 Mission Oaks Blvd. • PO Box 6009 • Camarillo, CA 93011 • (800) 444-3353